

IRISH CRANE & LIFTING LTD

Unit 2, Lissivigeen, Killarney, Co. Kerry - T: +353 (0)64 663 3722 - F: +353 (0)64 663 4233
 Unit 76b Cookstown Ind. Est., Tallaght, Dublin 24 - T: +353(0)1 451 0932 - F: +353 (0)1 451 0655

Hackett Push Trolley

This high quality trolley range is precision engineered in capacities from 500Kg to 10t.

Enabling exact positioning or easy traversing of large loads incorporating Manual hoists, the Hackett series push trolley can be supplied to suit various track widths with Beam Range 1 and the extended Beam Range 2.

The runners (trolley wheels) are precision machined and they rotate on maintenance sealed ball bearings.

All Hackett push trolleys are fitted with anti-jump bars.

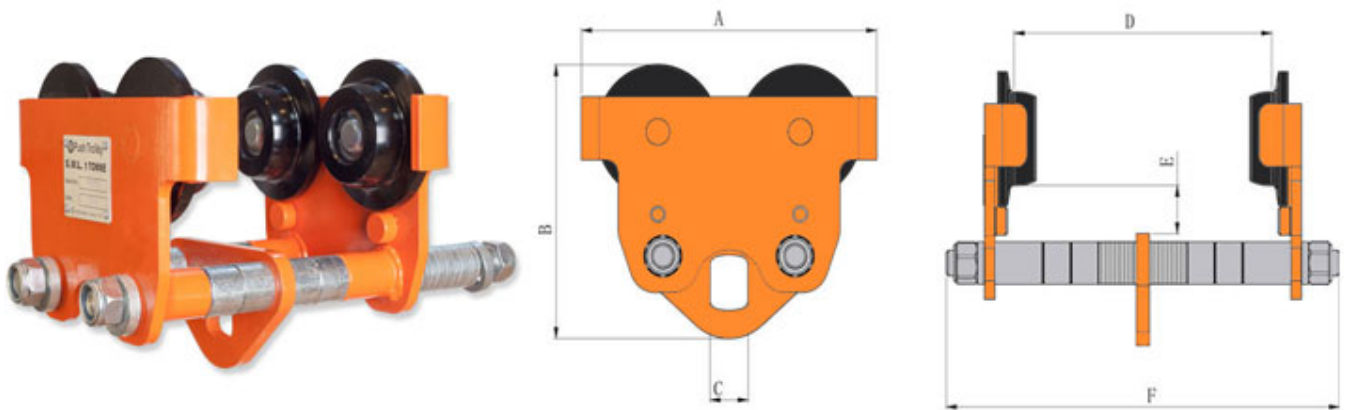

TECHNICAL SPECIFICATION

Part Code	Capacity (t)	Min.radius of curve (m)	Dimensions (mm)							Beam Range (mm)		Mass (kg)
			A	B	C	D	E	F	1	2		
044.050	0.5	0.8	200	166	22	203	34	289	50-152	50-203	6.5	
044.100	1.0	0.9	232	196	30	203	34.6	309	64-203	64-305	10.0	
044.200	2.0	1.0	260	226	37	203	34.5	318	88-203	88-305	15.5	
044.300	3.0	1.2	280	264	42	203	34.5	342	100-203	100-305	26.5	
044.500	5.0	1.3	312	271.3	50	203	34.2	362	114-203	114-305	36.0	
044.1000	10.0	2.0	376	334	58	206	37.1	392	124-203	124-305	67.0	